

HIVE™
BUILT BRIGHT

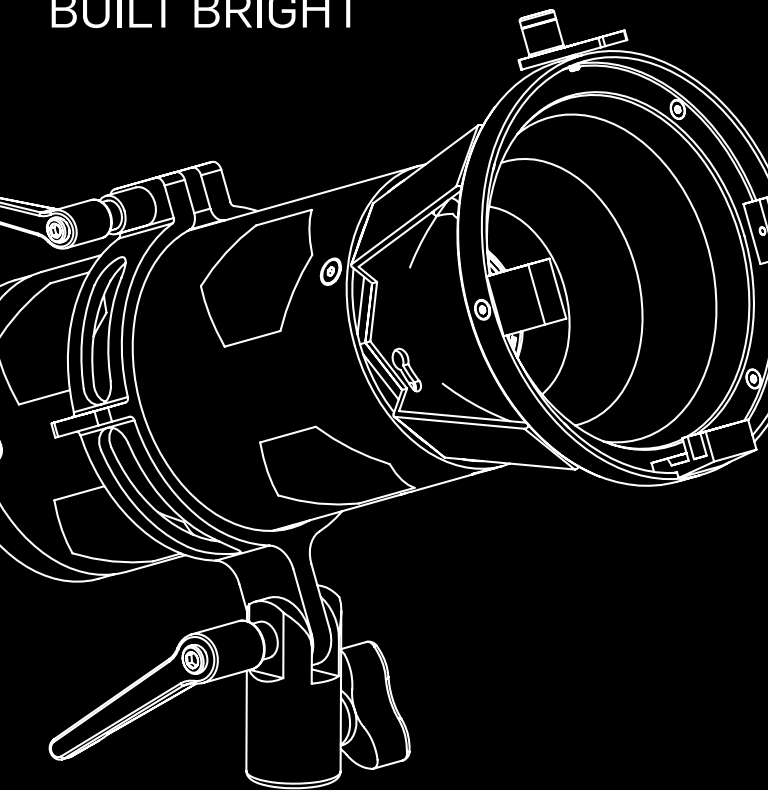

WASP 100-C™
USER MANUAL

WELCOME!

And thank you for your purchase of the Wasp 100-C™. The Wasp 100-C™ is an Omni-Color LED luminaire from Hive Lighting designed for use in permanent, semi-permanent and mobile lighting applications. Combining energy efficient LEDs with our Perfect S.H.O.T. controls we hope you find the Wasp 100-C™ to be the perfect instrument for any lighting application. We hope this manual serves as a helpful companion to your new light and answers all the questions you may have, but please do not hesitate to take advantage of our website and tech support services.

Sincerely,

Hive Lighting

Quickstart Guide

GETTING A PERFECTLY LIT SHOT IN JUST 3 STEPS



**1) Plug In and Power On
(Select Local Control)**



**2) Pick your S.H.O.T.
(Saturation, Hue, Output,
color Temperature)**



3) Shoot!

Table of Contents

Welcome!	1
Quick Start	2
Specifications	5
Safety Information	7
Safety Warnings & Precautions	7
Safety Guidelines	7
FCC Information	9
Caring for your Wasp 100-C™	9
Tips & Troubleshooting	10
Product Overview	11
Components & Included Accessories	11
Control Panel Features	12
Getting Started	13
Mounting The Light	13
Tilting (Vertical Adjustment)	13
Panning (Horizontal Adjustment)	14
Switching Lenses	14
Attaching the Barndoors	15
Removing the Reflector	15
Power	17
AC/DC Adapter (Included)	17
Battery (Sold separately)	17
Firmware Updates	18
Perfect S.H.O.T.™ Controls	18
Local Control	19
DMX Mode Instructions	20
App Control (Via Bluetooth)	22

Menu Tables	23
Policies	25
Product Modification Warning	25
Limited Warranty	25
Returning an Item Under Warranty for Repair	26
Refund Policy	28
Freight Policy	30

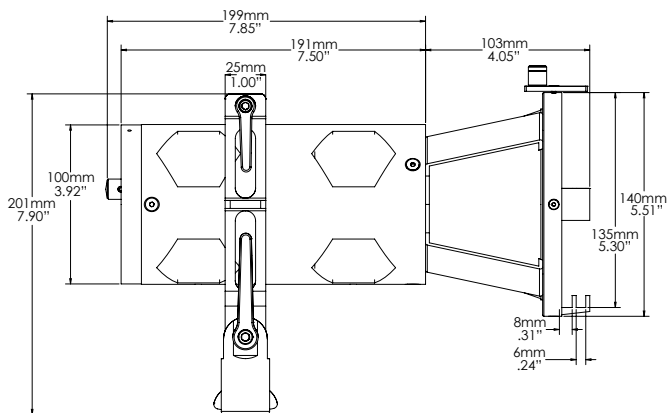
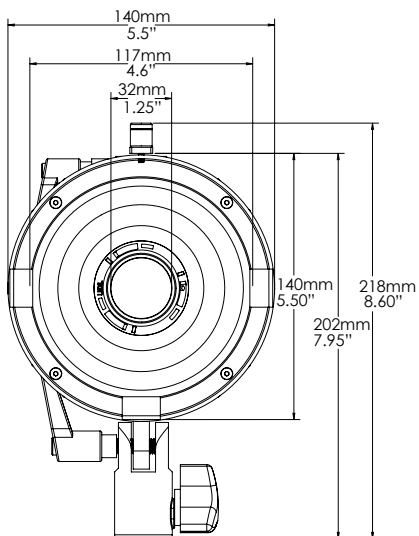

Specifications

- Lens type: HDP
- Optical System: Omni-Color LED
- Lens Diameter: 5"
- Weight: 5lbs
- Mounting: 16 mm receiver ("Baby" 5/8 inch receiver)
- Power Supply Range: 12-34V DC
- Power Consumption: 85W
- DC Power Connection: 4-pin XLR
- White Light: 1650K – 8000K Continuously Variable Correlated Color Temperature
- Colored Light: Full 360 degree color wheel Hue and Saturation control
- Color Temperature Tolerance: +/- 100K
- Dimming: 0 – 100%
- Control Options: 5-Pin DMX In and Out, In-Unit, app via bluetooth
- Data Input: USB
- Housing Color: Black
- Ambient Temperature Operation: -35 °C to 40 °C
- Estimated LED Lifetime: 50,000 Hours

Safety Information

SAFETY WARNINGS & PRECAUTIONS



- **WARNING: Risk of Electric Shock!** The Wasp 100-C™ is a lighting product powered by sufficient electricity to cause harm to the human body. Do not install or operate fixture while standing in water or underwater. Failure to observe this safety information or to ignore common sense may cause serious injury or even death.



- **CAUTION: High beam intensity!** Do not look directly into the light beam for an extended period. No UV or IR is emitted at any time from this fixture.



- **CAUTION: Devices and accessories must always be properly secured against fall when mounted above floor level.** Always observe common and local safety regulations.

GENERAL SAFETY GUIDELINES



- Defective components to the unit, attached cables or electronic devices connected to it must not be used. If you suspect there is damage to the product's internal components, do not open the housing. Doing so will void all warranties.



- Do not operate the light if you see that any cables or devices that light is connected to have been damaged.



- Product complies with DMX512 standards only. Light is not compliant with RDM standards and may not be operated with aid of an AC dimming system.



- Do not sit or submerge product in water.



- ONLY use DC Power source within acceptable voltage range of 12-34V DC - check that power source complies before handling. It is strongly recommended that the user powers light with either the provided AC/DC adapter or a Hive-approved battery adapter.



- Do not position or mount the product near open flames.



- Unobstructed airflow is required for effective cooling. Allow minimum of one inch clearance around air vents for proper ventilation.

FCC INFORMATION

This equipment has been tested and found to comply with the limits for a Class A digital device, pursuant to Part 15 of the FCC rules. These limits are designed to provide reasonable protection against harmful interference when the equipment is operated in a commercial environment. This equipment generates, uses, and can radiate radio frequency energy and, if not installed and used in accordance with the instruction manual, may cause harmful interference to radio communications.

Caring for your Wasp 100-C™

MAINTENANCE

Help prevent damage and prolong the life of your equipment by following these suggestions:

- With the unit unplugged, lightly clean the outer metal housing with a soft, clean towel and compressed air.
- Clean the control panel with cotton swabs wetted with isopropyl alcohol.
- Clean the reflector and lenses with a dry chamois or compressed air. Avoid touching any of these components with your fingers directly.



- Do not operate product when operating environment is in excess of 50 °C.



- Do not misuse the power connector to hold, move or suspend the fixture.
- Disconnect all cables prior to transport.
- Store light in a cool dry place (between 5 - 20°C) .

TIPS & TROUBLESHOOTING

It is rare but possible for the reflector to become unfixed, either during transport or during storage. If this happens, simply re-secure it by twisting it clockwise until the reflector plate engages the pins locking it into place.

It is generally acceptable to operate the light on external shoots but when operating the light in damp or wet conditions be sure to monitor the light to ensure that no water is accumulating inside of the housing.

When using a battery pack, remember that the light uses 80W when at full output. This requires a battery with a minimum power rating of 90Wh, although we recommend batteries rated for 100 Wh or higher and with a minimum 10 amp hour fuse. Exact run time is based on the individual battery's storage capacity.

If you need to adjust one of many Wasp 100-C™ units via the app and have forgotten what it is named in the app's scan results, try reducing the Bluetooth Discovery Distance to 1 meter (available in the app's main settings) and rescan with your phone next to the specific light in question.

Product Overview

COMPONENTS AND INCLUDED ACCESSORIES

Components of the Wasp 100-C™ and Included Accessories

1. Housing - This metal casing is the shell that protects the more sensitive internal components of the light and should not be opened for any reason.
NOTE: Opening the housing risks voiding all warranties.
2. Control Panel - Contains the digital display, controls and ports for the light.
3. Reflector - This comes attached to the light, and it can be removed from the housing to accommodate other light modifying accessories by gently twisting it counter-clockwise.
4. Yoke - Used when attaching some accessories and for mounting the light.
5. Lenses - The Wasp 100-C™ comes with 4 interchangeable HDP Lenses (medium, wide, super wide) and lens bag.
6. AC/DC Adapter and Power Cable (Not Pictured) - ONLY use DC Power source within acceptable voltage range of 12-34V DC. Using any DC voltage outside this range will void the product warranty.
7. Barndoors - Accessory used for light-shaping.

NOTE: The Wasp 100-C™ is compatible with a broad range of Hive-branded and third party accessories. For more information, please visit Hive's website at <http://hivelighting.com/hive-products/accessories>.

CONTROL PANEL FEATURES

8. On/Off Switch - Controls Power. The power light above the display illuminates when power is on.
9. DMX Mode On/Off Switch - Controls DMX mode when unit is attached to DMX board. (See page 20 for more instructions.) The DMX indicator light, above the display, illuminates when Wasp 100-C™ is in DMX mode.
10. Left "Selector" Knob - Selects the S.H.O.T.™ property.
11. Right "Adjustment" Knob - Selects S.H.O.T.™ property's desired value. When in DMX mode, this knob is used to adjust the light's starting address.
12. DMX IN Socket - Connect Wasp 100-C™ to your DMX board via a 5-pin XLR cable.
13. DMX OUT Socket - Connect Wasp 100-C™ to another light via a 5-pin XLR cable when using one DMX board to control multiple units. The Wasp 100-C™ follows DMX512 standards, allowing multiple lights to be "daisy chained" together.
14. Power Socket - Connect Wasp 100-C™ to valid power source via the 4-pin XLR power cable that comes included with adapter (For XLR pin wiring

pin 1 - DCV In and pin 4 + DCV In).

15. Display - Provides digital readout for values of all controllable light properties.
16. USB Port - Used to connect light to computer when firmware updates are made available by Hive.

Getting Started

MOUNTING THE LIGHT

The Wasp 100-C™ may be operated when securely mounted to a separate apparatus, such as a stand (purchased separately).

1. Carefully position the light above stand.
2. Place the top of the stand into the mount, located on the base of the yoke.
3. Continue to hold the light securely with one hand, and use the other to twist the mount's locking knob clockwise until tight.

TILTING (VERTICAL ADJUSTMENT)

1. Loosen the tilt lock on the yoke until light can move freely.
2. Adjust the light upward or downward at any angle between 0° and 180° (Vertical).
3. Secure the tilt lock once desired angle is reached.

PANNING (HORIZONTAL ADJUSTMENT)

1. Loosen the mount lock on the yoke.
2. Freely adjust the light left to right up to a full 360° horizontal rotation.
3. Secure the mount lock once desired angle is reached.

SWITCHING LENSES

Your Wasp 100-C™ comes with 4 interchangeable HDP Lenses: Medium, Wide and Super Wide. To affix these to the device, follow these steps:

1. Rotate the top clip until it is parallel to the reflector face
2. Slide the desired lens into the reflector cage's inner lens stage, or slot (pictured on page 16).
3. Rotate the top clip back into its locked position.
4. Rotate lenses with elliptical beams in order to position light projection in desired location.

ATTACHING THE BARNDOORS

The barndoors can allow for greater control in shaping the light. To attach:

1. Rotate the top clip until it is parallel to the reflector face
2. Slide the barndoors into the reflector cage's outer lens stage, or slot.
3. Rotate the top clip back into its locked position.
4. Adjust one or more of the leaves (i.e. "doors") of the barndoors to cut or shape the beam of light emitted by the Wasp 100-C™.

REMOVING THE REFLECTOR

The reflector and the cage that it sits in can be removed from the housing in order to accommodate a different accessory, such as an alternative reflector or softbox.

1. Press firmly on reflector cage and twist counterclockwise to release reflector plate from locking pins.
2. Rotate counterclockwise and pull loosely until free.
3. To reattach, center the reflector's keyed grooves over the housing pins, insert, and rotate clockwise.

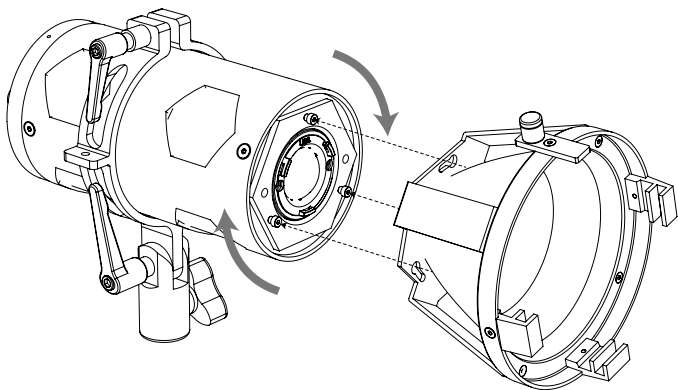
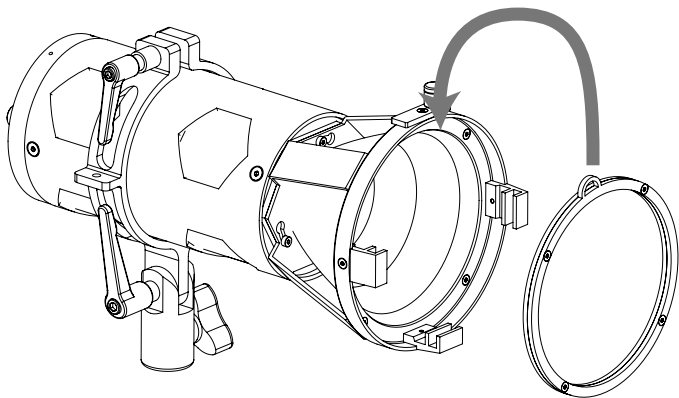

Power



ONLY use 24VDC Power source within acceptable voltage range of 12-34V DC.

There are two options for powering the light:

AC/DC ADAPTER (INCLUDED):

1. Connect the provided AC/DC adapter to the light via the the 4-pin XLR cable (XLR pin wiring pin 1 - DCV In and pin 4 + DCV In), which is inserted into the corresponding power socket on the light's control panel.
2. Connect the adapter's power cable into the wall or to a generator.
3. Turn the Wasp 100-C™ on by flipping the power switch to the "on" position (up), located on the control panel, causing the power indicator light to illuminate.

BATTERY (SOLD SEPARATELY):

1. Attach the battery's Dtap to 4 pin XLR adapter cable to the battery, with the other end connecting to the light via the power socket in the control panel.
2. Turn the light on by flipping the power switch to the "on" position (up), located on the control panel. This will cause the power indicator light to illuminate.

NOTE: Remember that the light uses 80W per second when at full output. This requires a battery with a minimum power rating of 90Wh, although we recommend batteries rated for 100 Wh or higher and with a minimum 10 amp hour fuse. Exact run time is based on the individual battery's storage capacity.

Firmware Updates

The Wasp 100-C™ is designed to receive periodic firmware updates, which will be made available via Hive. Once notified, connect your unit to your computer via a USB cable using the USB port in order to complete the firmware installation.

Perfect S.H.O.T.™ Controls

The light emitted by the Wasp 100-C™ can be configured via Hive's Perfect S.H.O.T.™ system, which controls these four properties:

- Saturation (denoted by "S" on the display)
- Hue (denoted by "H" on the display)
- Output or Dimming (denoted by "D" on the display)
- Color Temperature (denoted by "K" for degrees in Kelvin when in local mode, or by "C" when in DMX mode.)

There are three ways to use the Perfect S.H.O.T.™ system:

1. Locally, using the light's own digital control panel. Local control is useful for those who don't have access to a DMX board, or who are working on simpler projects.
2. Via a DMX board (purchased separately). When in this mode, the Perfect S.H.O.T.™ system is controlled via this external device, with a fifth property - the board's starting address - controlled on the light itself.
3. Via the Hive iOS App, which allows your iphone or ipad to control the app via a bluetooth connection.

LOCAL CONTROL

1. Engage Local Mode: Flip the DMX On/Off Switch to the down position, causing the DMX light to turn off. You are now in LOCAL MODE, and the digital display will look like this:



IMPORTANT: In local mode, color temperature is indicated by the letter "K" because the color temperature range of 1650 - 8000 is in degrees Kelvin.

2. Select Property With Left Dial: Turn the left dial in either direction to toggle through the four properties.

3. Select Property Value with Right Dial: There are two ways to select the property value with the right dial.
 - a. Fine Adjustment: Press the right dial in slightly, then continue to press in the dial while turning in either direction to change the active property's value by increments of 1. (The exception is Color Temperature, which adjusts in increments of 25).
 - b. Coarse Adjustment: Turn the right dial in either direction. The active property's value will now change in increments of 10 (with Color Temperature incrementing by 100).

NOTE: Local Mode will always default to the last setting it had before being turned off.

DMX MODE INSTRUCTIONS

1. Connect DMX Board: Connect your DMX512-compliant device to the Wasp 100-C™ via the DMX "In" Socket on the right side of the Control Panel
2. Engage DMX Mode: Flip the DMX Mode On/Off Switch to the up position, causing the DMX indicator light to turn on. This light tells you that you are now in DMX mode and can use a DMX board to control the light. Your digital display will look like this and will register value changes via the connected DMX board.
3. Adjust Starting Address: You will also notice that there is a fifth symbol when in DMX mode - "A". This indicates the light's starting address, and its value determines which controls on the DMX

board are used to operate the light. The starting address can be any value between 1 and 512.

Selecting the one you want can be achieved in two different ways via the control panel's Right Dial:



- a. Fine Adjustment: Press the right dial in slightly, then continue to press in the dial while turning in either direction to change the active property's value by increments of 1.
- b. Coarse Adjustment: Turn the right dial in either direction. The starting address' value will now change in increments of 10.

NOTE: Any values for S, H, D & C that have been provided by the DMX board will persist even after the DMX board has been unplugged. Conversely, if the controls on the DMX board are adjusted post-separation and then the board is reconnected, the light will read the updated values, overwriting the previous ones.

DMX CHANNELS

Channel	Property	DMX 0	DMX 255
Channel 1	Dimming	Off	Full brightness
Channel 2	CCT control	1,650K	8,000K
Channel 3	Saturation	0% Saturated (White Light)	100% Saturated (Full Color)
Channel 4	Hue	0 Degrees hue	360 Degrees Hue

APP CONTROL (VIA BLUETOOTH)

1. Download the iOS app to your iPhone or iPad that is running iOS 8.1 or later as well as Bluetooth 4.0 or later.
2. Make sure Wasp 100-C™ is on.
3. Turn on your iOS device's Bluetooth connection.
4. Open the app on your device & Click "Scan."
5. Find your Wasp 100-C™ in the scan results, indicated by the serial number of the LED array itself. This is the unique address of the light.
6. Click on your light in scan results and your mobile device will attempt to make a Bluetooth connection.
7. Once connected, use the sliders for the four S.H.O.T.™ properties to control the light wirelessly. Your unit will respond in real time. For more information on the value ranges in the app, see the tables on the following pages.

NOTE: Control of the light via the app will override any input from DMX board or local controls. However, adjustment of S.H.O.T.™ values in app will NOT be reflected in the light's digital display.

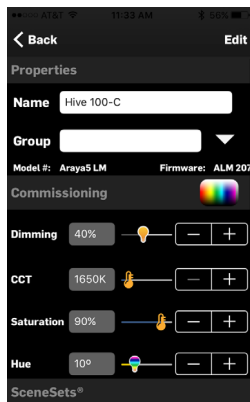

Policies

SATURATION

	App Control	Local Control
Menu Symbol	Saturation	S
Value Range	0-100	0-100
Fast Control	Slider in app	Right Knob Default
Fine Control	Type in exact value	Right Knob Push In and Hold
Fast Control Increments	NA	10
Fine Control Increments	1	1

HUE

	App Control	Local Control
Menu Symbol	Hue	H
Value Range	0-360	0-360
Fast Control	Slider in app	Right Knob Default
Fine Control	Type in exact value	Right Knob Push In and Hold
Fast Control Increments	NA	10
Fine Control Increments	1	1

OUTPUT

	App Control	Local Control
Menu Symbol	Dimming	D
Value Range	0-100	0-100
Fast Control	Slider in app	Right Knob Default
Fine Control	Type in exact value	Right Knob Push In and Hold
Fast Control Increments	NA	10
Fine Control Increments	1	1

TEMPERATURE

	App Control	Local Control
Menu Symbol	CCT	K (for Kelvin)
Value Range	1650-8000	1650-8000
Fast Control	Slider in app	Right Knob Default
Fine Control	Type in exact value	Right Knob Push In and Hold
Fast Control Increments	NA	100
Fine Control Increments	1	25

DMX

	DMX Control
Menu Symbol	A
Value Range	1-512
Fast Control	Right Knob Pushed In
Fine Control	Right Knob Default
Fast Control Increments	10
Fine Control Increments	1

PRODUCT MODIFICATION WARNING



Hive Lighting Inc. products are designed and manufactured to meet the requirements of United States and International safety regulations. Modifications to the product could affect safety and render the product noncompliant to relevant safety standards. Any evidence of attempted repair by non-authorized staff, such as opening of the light's housing, will void all warranties.

LIMITED WARRANTY

The Wasp 100-C™ and all of the included accessories is covered by a two year, limited non-transferable warranty, which may entitle the original owner of the product to repair and/or replacement services by a Hive-certified technician, provided damage is incurred as a result of reasonable use*. Coverage begins on the date of original purchase.** For

information on shipping protocol in the event of damage to your unit, see the next section on returns.

- **Housing:** An extended warranty may be purchased on the housing. Please contact Hive for more details.
- **Electronics:** Do not attempt to open the housing if owner suspects any damage to the electronic components enclosed within. Doing so will immediately void the warranty. Instead, contact Hive about repair services that you may be entitled to.
- **Shipping Damage:** Although rare, this warranty also covers any damage incurred during initial shipment of the equipment. If this happens, please contact Hive immediately so that we may resolve the issue as quickly as possible. Please include your order number with all email correspondence.

**For any questions on what constitutes reasonable use, please ensure that product operation adheres to the safety guidelines at the beginning of this manual.*

***It is the owner's responsibility to furnish receipts or invoices for verification of purchase, date, and dealer or distributor. If purchase date cannot be provided, date of manufacture will be used to determine warranty period.*

RETURNING AN ITEM UNDER WARRANTY FOR REPAIR

Once you are certain that the requested repair adheres to the warranty outlined above, follow these return instructions to ensure prompt service from Hive:

1. Email Hive at sales@hivelighting.com with the

following information prior to shipment:

- Owner's Name
- Owner's Phone Number
- Components Damaged
- Description of Damage
- Date of Purchase
- Serial Number of unit (This is laser etched into the body of the light itself both on the inside and outside of the Interface Back Cap).
- Order Number, which can be located on Invoice or Receipt from Hive Lighting or a Hive Lighting authorized reseller.

Hive will need this information when making the final determination as to whether or not the unit is covered by warranty. Please expect a response within 5-7 business days. If approved, Hive will assign your repair request with a Return Material Authorization (RMA) number, which will be provided to you via email.

2. Once approved, carefully package the equipment so as to ensure its protection during shipment. This packaging must be clearly and prominently marked to indicate that the package contains returned product units or parts. Owner must pay for shipping costs when returning equipment for repair.*
3. Include your RMA number along with equipment being returned.
4. Ship returned equipment to:
Hive Lighting

525 S Hewitt St
Los Angeles, CA 90013

5. Once item has been received, Hive will contact you within 2 business days with an estimate of repair time needed. Hive will cover shipping costs when returning repaired or replaced equipment to purchaser within continental United States only. See Freight Policy below for more information.

**Because of this, we strongly recommend that you return the item(s) to us via a recorded delivery service or courier that will offer proof of delivery. We also recommend that you insure the return shipment as Hive is not responsible for packages that are lost or damaged in transit.*

REFUND POLICY

Hive provides refunds equal to the original purchase price, less any shipment costs incurred in original shipment or upon return. This refund may be obtained if the purchased equipment fulfills the following acceptance criteria:*

- Unit is returned to Hive within 14 business days after owner receives it.
- There is no damage to unit or any of its accessories.
- Unit has not been altered from the original condition in which it was purchased
- Unit is returned with all the packaging intact.
- All accessories included in the original shipment are returned in addition to the Wasp 100-C™. Hive does not provide partial refunds.
- Equipment shows no signs of heavy use.**

If you believe all acceptance criteria is met, follow these steps to ensure refund eligibility:

1. Notify us at sales@hivelighting.com of your intention to return the item within 7 days after the date you receive the product. Please be sure to include your name, phone number, serial number (laser-etched on the unit itself) and the order number of your purchase in the email. The order number can be found on the invoice or receipt from Hive Lighting or a Hive Lighting authorized reseller.
2. Ship equipment*** in its original packaging to:
*Hive Lighting
525 S Hewitt St
Los Angeles, CA 90013*
3. Hive will issue a refund to the owner for the returned item(s) (minus the initial delivery charge) to the original credit or debit card used during purchase, once it is determined that all acceptance criteria has been met.

**light and all accessories included in shipment.*

***Refunds are generally reserved for customers who have a legitimate concern or change in their lighting needs. We reserve the right to decline a refund if it is suspected that the light has been used for a legitimate shoot.*

****Because Hive does not refund shipping costs, we strongly recommend that you return the item(s) to us via a recorded delivery service or courier that will offer proof of delivery. We also recommend that you insure the return shipment as Hive is not responsible for packages that are lost or damaged in transit.*

FREIGHT POLICY

The purchaser will pay all shipping charges. Items under warranty shall have return shipping paid by the manufacturer only in the continental United States. Under no circumstances will freight collect shipments be accepted. Prepaid shipping does not include rush expediting such as airfreight. Airfreight can be sent customer collect in the continental United States. REPAIR OR REPLACEMENT AS PROVIDED FOR UNDER THIS WARRANTY IS THE EXCLUSIVE REMEDY OF THE CONSUMER. HIVE LIGHTING INC. MAKES NO WARRANTIES, EXPRESS OR IMPLIED, WITH RESPECT TO ANY PRODUCT, AND HIVE LIGHTING INC. SPECIFICALLY DISCLAIMS ANY WARRANTY OF MERCHANTABILITY OR FITNESS FOR A PARTICULAR PURPOSE. Warranty is void if the product is misused, damaged, modified in any way, or for unauthorized repairs or parts. This warranty gives you specific legal rights; you may also have other rights, which vary from state to state. Freight damage claims are invalid for fixtures shipped in non-factory boxes and packing materials.

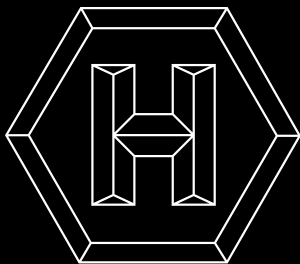

WWW.HIVELIGHTING.COM